

A MINIATURE STEAM VEHICLE: A NONHOLONOMIC MOBILE PLATFORM FOR THE DEVELOPMENT AND TESTING OF SIGNAL CONDITIONING CIRCUITS

JOÃO C. CASALEIRO¹, TIAGO S. OLIVEIRA², MIGUEL C. GOMES³, ANTÓNIO C. PINTO⁴,
PEDRO V. FAZENDA⁵

^{1,2,3,4,5}*Instituto Superior de Engenharia de Lisboa, DEETC, SEA, CEDET*

¹*joao.casaleiro@cedet.isel.ipl.pt*

This document describes a small steam vehicle built by students and teachers which is in use in one specific course context focused in applied electronics. This vehicle was built with a steam engine and all the necessary gears to transmit movement to the driving wheels. Several sensors and actuators were also included. This apparatus may be observed as a simple nonholonomic mobile platform for exercising the development of signal conditioning circuits and control algorithms.

1. Introduction

This document describes an apparatus that may be observed as a simple nonholonomic mobile platform for exercising the development of signal conditioning circuits and control algorithms. This apparatus is in fact a small steam vehicle made from standard Meccano parts (aprox. 30 cm length), which was built by students and teachers. It is actually in use in one specific course context focused in applied electronics. This vehicle has a steam engine and all the necessary gears to transmit movement to the driving wheels. Several sensors and actuators were also included and a black-and-white camera was placed near the front bumper of the vehicle. Sensors and actuators with minimal built-in signal conditioning (or no signal conditioning at all) were chosen so that students may conceive their own circuits. The idea is to use this apparatus as a test bench for some of the topics covered in the course.

Figure 1 presents a photo of this vehicle. The trailer is not always used, but it might be necessary to carry circuit boards or batteries. A schematic diagram of the vehicle showing the set of sensors and actuators is depicted in figure 2.

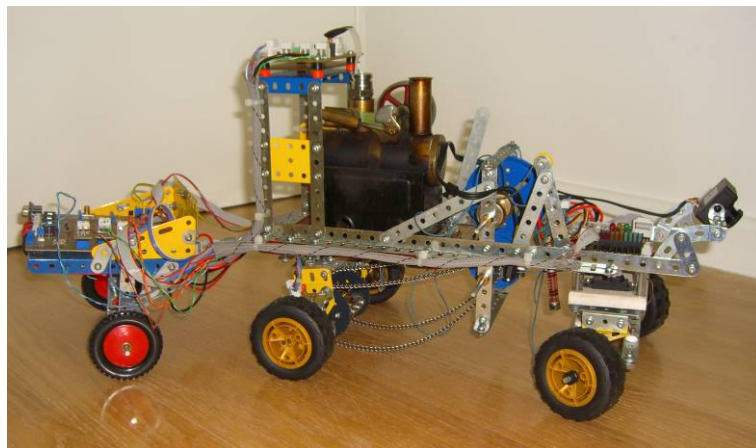

Figure 1: Photo of the steam vehicle.

2. Sensors and Actuators

When using the platform in this course context students are challenged to pursuit some goal. To achieve it, they must foresee a list of tasks. To fulfil these tasks students may choose to use a subset of

these sensors and actuators or even propose to add others more specifically fitted to suit their needs. For example, one of the main tasks is knowing when to start the steam engine, which implies measuring the steam pressure inside the boiler and the flame temperature.

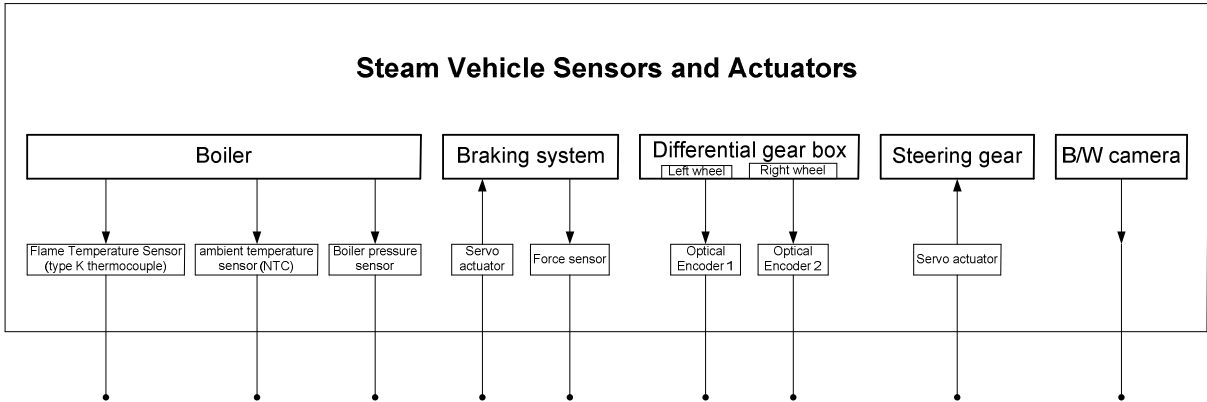

Figure 2: Schematic diagram of the steam vehicle sensors and actuators.

2.1. Pressure and Temperature

After igniting the fuel, the pressure inside the boiler increases until a ready-to-start threshold is achieved. The steadiness of the flame temperature insures that the pressure is maintained high enough to keep the engine moving. Students must detect this event in order to start the run. Figure 3 shows a graphic depicting the steam pressure and flame temperature during a short run.

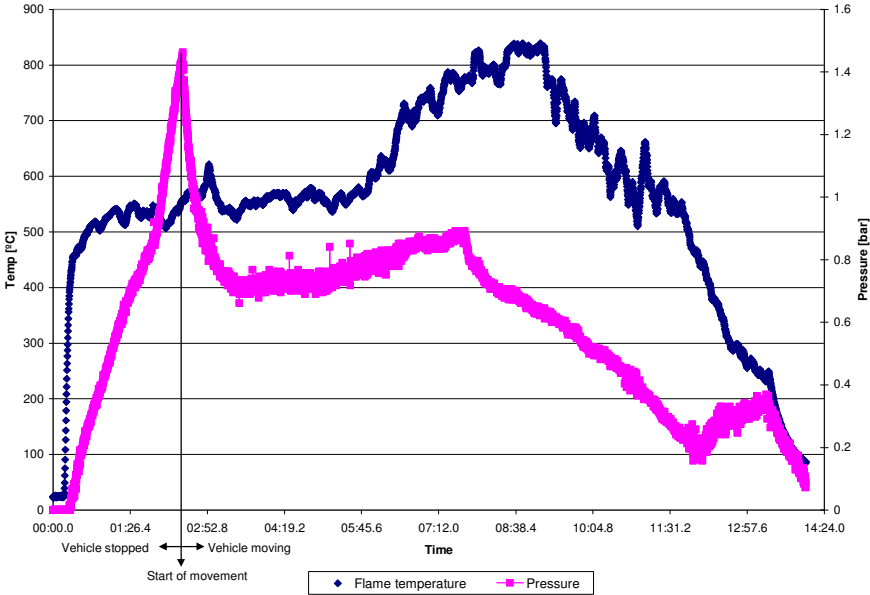

Figure 3: Steam pressure and flame temperature.

To measure the flame temperature, a type K thermocouple is located just below the boiler, as can be seen in figure 4. Another temperature sensor is placed near the cold junction created in the connector to enable a temperature reference for this thermocouple. This sensor is an NTC thermistor. Both sensors, the thermocouple and the thermistor, have no signal conditioning at all, so students must develop the necessary circuits to interface them to the controller system.

The signal conditioning circuit that students use with the thermocouple is normally composed of an instrumentation amplifier, as the one depicted in figure 5. As for this sensor, a polynomial approximation may be used to characterize its response. Sometimes a linear response can also be assumed. The biggest challenge students face with this sensor is its low voltage output and the need to maintain a low current through it in order to minimize self-heating error.

The NTC thermistor serves as an example of a sensor with a non-linear characteristic but characterized by a known model. When using NTC thermistors, students almost always employ the commonly used [1] two parameter equation $R_T \approx R_0 e^{\beta \left(\frac{1}{T} - \frac{1}{T_0} \right)}$, adopting for R_0 and β the typical values provided by the manufacturer’s datasheet. Some students try to validate this equation and its parameters by testing its results against some form of reference, usually an ordinary mercury thermometer. This attitude is welcome because it exercises the students’ critical capabilities concerning the use of the so called “typical values”, too often effortlessly applied for fast attainment of results without the mandatory validation in precision measurement situations.

To measure the boiler’s internal pressure, there is a pressure sensor placed on top of the boiler as can be seen in figure 6. This sensor and the thermocouple have a major role in the steam engine control, as they provide the most relevant data concerning the actual mechanical power available.

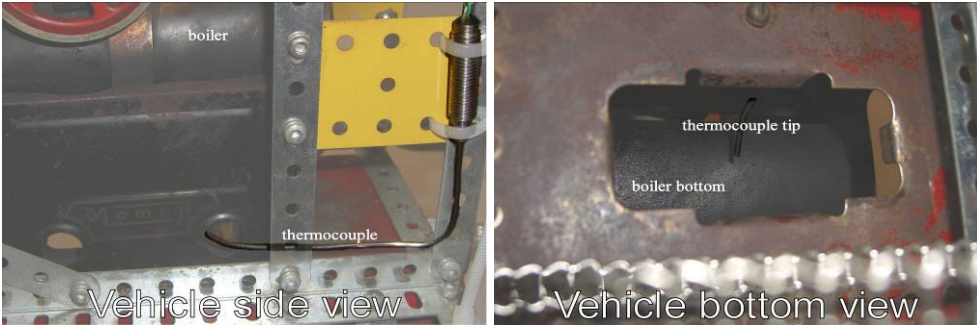

Figure 4 : Thermocouple location underneath the boiler (above the burner tray).

The electric model of the pressure sensor is also shown in figure 6: it is a resistive Wheatstone bridge whose differential output voltage is proportional to the difference between atmospheric pressure and the internal boiler’s pressure. Internally, the sensor has a small diaphragm placed between two chambers connected to the pressure ports: the atmospheric pressure port and the boiler’s pressure port. This diaphragm undergoes some deformation when a differential pressure is applied. Four piezoresistors deployed in the diaphragm form the Wheatstone bridge. This topology is frequently used in inexpensive differential pressure sensors [2]. As most sensors in this platform, this sensor does not have any kind of built-in signal conditioning.

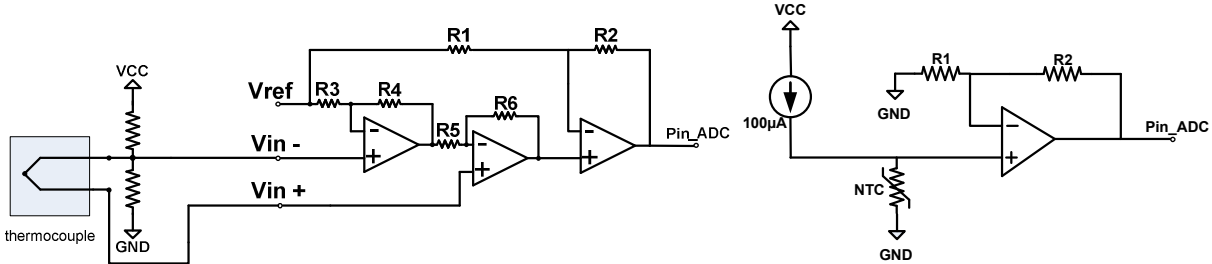

Figure 5 : Student’s example of signal conditioning circuits for thermocouple and thermistor sensors.

The model that students use for the pressure sensor is a linear one, with a known sensibility which is ratiometric to the sensor's supply voltage. This sensor is internally compensated for temperature, so students don't normally have to deal with it, although they might want to make some adjustment to measurements if the boiler's temperature exceeds the compensation temperature range.

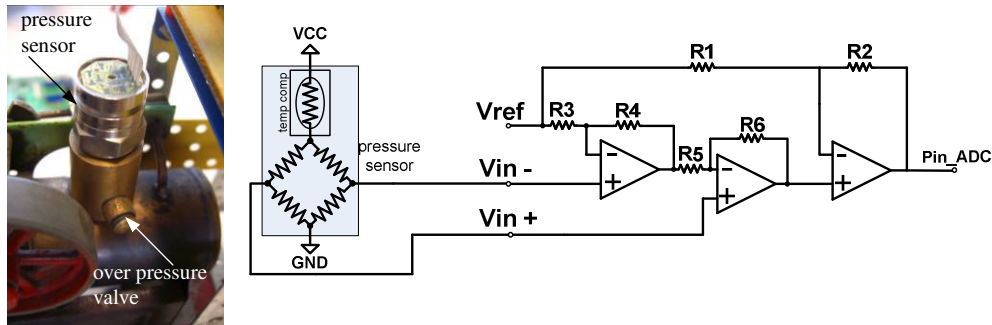

Figure 6 : Student's example of a signal conditioning circuit for the pressure sensor.

2.2. Braking system

Another task that students may be challenged to solve is the control of the vehicle's braking system. This system works by controlling the friction done by a belt over a metal pulley. Tension is applied (or released) to this belt by a small servo motor, tightening (or loosening) the belt and increasing (or decreasing) the friction. A force sensor is used to measure the applied tension to the belt. Too much tension might damage (in the long run) the mechanism by bending the pulley's axle too much. Also, if insufficient tension is applied, the vehicle won't come to a full stop, so some sort of controlled action must be achieved.

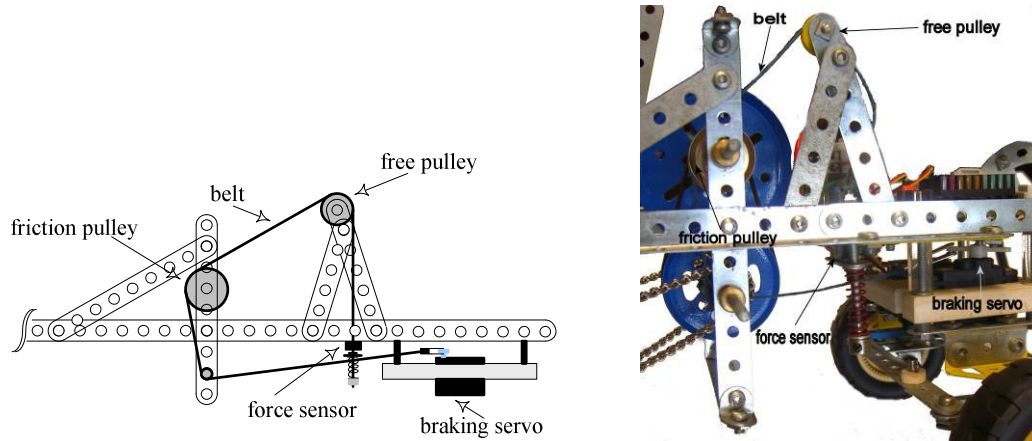

Figure 7 : Braking system (schematic diagram and photo).

Students have to fully understand this braking system to be able to actuate upon it. Figure 8 shows a graphic depicting the characteristic function of the braking system. Note that although it is a monotonic function, the traction force made by the belt isn't a linear function of the servo angle. Students do not know this function, and so they have to envisage some tests in order to manually extract it. Then, after getting some experimental data points, they might interpolate them either by a polynomial function or by linear approximation functions. Although the servo angle vs. force function is non-linear, the force sensor itself has a linear response, with a differential output voltage proportional to the measured force (its sensibility is ratiometric to the supply voltage). Internally, the mechanical construction of this sensor is similar to the pressure sensor but without the air chambers [2].

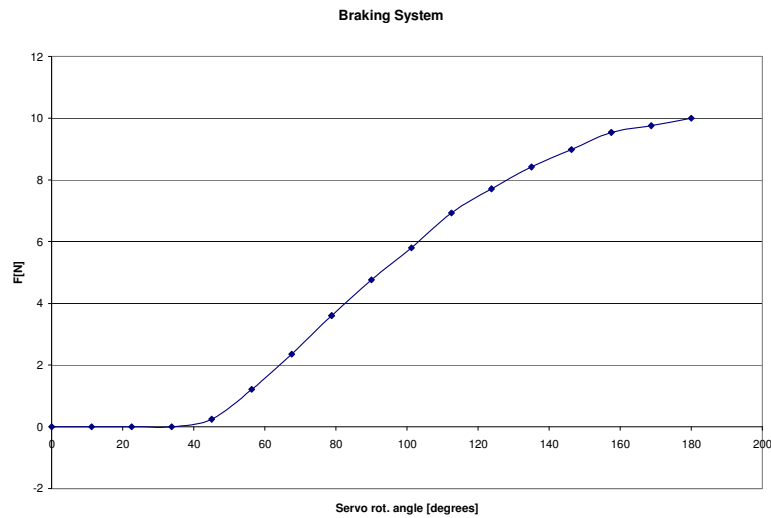

Figure 8 : Characteristic function of the braking system.

To interface this sensor, an instrumentation amplifier similar to the one used with the thermocouple can also be used. Figure 9 shows this configuration.

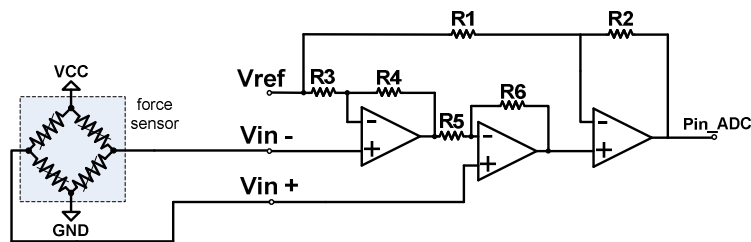

Figure 9 : Example of a signal conditioning circuit for the force sensor.

2.3. Optical encoders

To measure the actual speed and the total distance traveled by the vehicle, there are two quadrature optical encoders placed in the independent rear wheels axle-shafts, as depicted in figure 10. Since the vehicle has a differential gearbox in the rear wheels shafts, these encoders measure different angular speeds when the vehicle is turning, and because they have a quadrature output it is possible to know the direction of the shaft rotation.

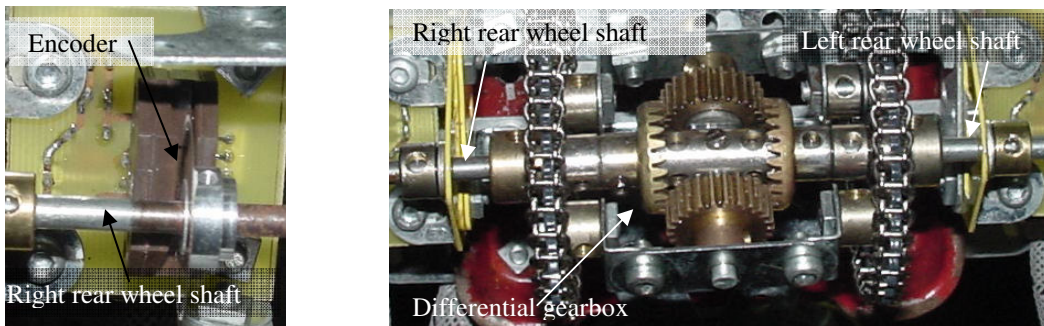

Figure 10 : View of one encoder and of the differential gearbox.

Also, by using a differential gearbox, the vehicle can perform tight turns since the rear wheels, which are the traction wheels, can spin at different speeds; they may even rotate in opposite

directions. Each encoder has three open collector interfaces that provide rectangular signals: two of them, having a phase difference, encode the angular speed and the spinning direction, and the third one is a full-revolution pulse.

2.4. Steering gear

This vehicle has a steering gear actuated by a small servo, as depicted in figure 11. The front wheels have two free independent axle-shafts whose direction is controlled by the servo. This steering gear allows the vehicle to execute turns to about 36 cm radius.

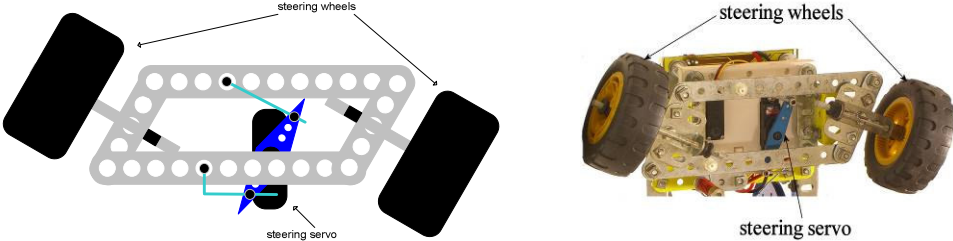

Figure 11 : Vehicle’s steering gear.

The steering servo may be used with its own controller, in which case the input used to drive the servo is a width modulated pulse, as normally used in radio control models. This servo can be presented to students without its internal controller, becoming a five wire servo: two wires for the servo’s DC motor and three wires for the absolute position encoding potentiometer. It’s a teacher’s chore to decide which challenge should be offered to a particular student (or group). In this last option (five wire servo), a feedback sub-system to control position is created around the steering gear, and it must be studied and understood by students to become useful.

3. Control unit

In order to achieve the purposed goal, students develop the signal conditioning circuits and interface them to some sort of processing unit. The selection of this unit considers several factors. One of the main factors is the amount of data to be processed and the required processing speed. For example, the camera can be used to steer the vehicle by following a white line drawn over some dark surface. In this case, the choice for the processing unit is probably a DSP, although some microcontrollers or an FPGA based controller may be used.

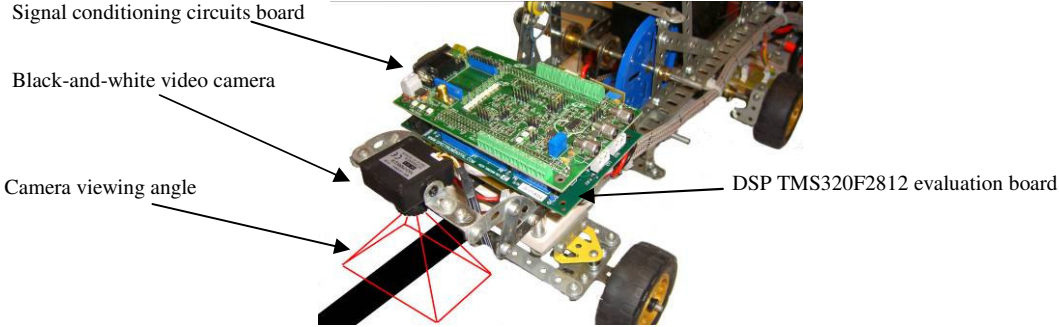

Figure 12 : Vehicle’s front view showing two circuit boards and video camera.

As an example, in figure 12 is shown the steam vehicle transporting two boards: a DSP TMS320F2812 evaluation board and a custom built interface board. These two boards fully control the vehicle, and interface the DSP to all sensors and actuators of the platform, including the black-and-white video camera and an FM radio serial data transceiver.

4. Final remarks

In some academic contexts there is the need to study the electronic circuits used for signal conditioning of sensors and actuators. It is the author's experience that it is much more motivating for students if this is done in such a context where these sensors or actuators are part of a process to be controlled, even if it's just for academic purposes, as long as real hardware (sensors and actuators) are used. Also, by including these sensors and actuators in a closed chain system (or several closed chain sub-systems), students are able to perform numerous experiences to evaluate their knowledge of control theory. The relevance of the study of feedback systems and, in a broader sense, the study of control systems, is often stated in articles with a pedagogical nature [3], [4], [5], even if only simple or basic concepts are involved. It is true that there are experimental setups commercially available dedicated to feedback controlled experiments, but these are usually intended for specific tasks, with particular sets of experiences in mind, and they often include sensors with built-in signal conditioning. Because the focus of such setups are frequently the control theory validation (typically for algorithm development and testing), there isn't much room left for the development of electronic circuits to accomplish the signal conditioning of sensors and actuators, either for simple displaying or for interfacing with a microcontroller (or some other computational system). To fulfill this need in a specific electronic course, the authors developed the experimental platform described in this document.

Although the platform described in this document may be seen as a set of several sub-systems, students are encouraged to exercise an attitude towards the system as a whole and to focus in the global problem to be solved instead of an approach too much biased in the isolated device or on the individual task. This attitude focused on the whole process is often the case in engineering works [6].

In the Portuguese academic *métier* this kind of enterprises are far from being frequent, maybe because teachers find it not worthy, bearing in mind the time-consuming characteristic of these activities. As it is common knowledge in our academic scene, "*The amount of effort that the academic staff dedicates to pedagogical activities is relatively small. These activities are much less rewarded than research activities*" [7]. Nevertheless, it's the opinion of the authors that these pedagogical experiences are important in the continuous search for better teaching techniques and results.

Acknowledgements

The authors wish to thank CEDET (<http://www.cedet.isel.ipl.pt>) for the resources made available for this work. CEDET is an acronym for "Centro de Estudos e Desenvolvimento de Electrónica e Telecomunicações" which is a center for investigation and development of electronic and telecommunication systems of the polytechnic institute ISEL.

References

- [1] Areny, Ramón Pallás, *Sensores y Acondicionadores de Señal*. 3^a Ed., Marcombo Boixareu Editores, Barcelona, 1998.
- [2] Tandeske, Duane, *Pressure Sensors*, Ed. Marcel Dekker, New York, chapter 5, pp. 77-115, 1991.
- [3] Albright, Robert J. and Hoffbeck, Joseph P., "Discovering the Effects of Feedback on Control Systems: Informative and Interesting Numerical Exercises", *IEEE Transactions on Education*, 44(2), pp. 104-108, 2001.
- [4] Eydgahi, Ali M. e Ghavamzadeh, Mohammad, "Complementary Root Locus Revisited", *IEEE Transactions on Education*, 44(2), pp. 137-143, 2001.
- [5] Giron-Sierra, José Maria, "A Simple Device and a Project for the Nonlinear Control Systems Laboratory", *IEEE Transactions on Education*, 44(2), pp. 144-150, 2001.
- [6] Teixeira, I. C. e Teixeira, J. P., "Trends on Microelectronics Systems Education", T. J. Mouthaan and C. Salm (eds.), *Microelectronics Education*, pp. 117-120. Kluwer Academic Publishers, Holanda, 1998.
- [7] Pereira, Manuel Seabra, *European Pilot Project for Evaluating Higher Education: An Exchange of Experiences in Engineering Programmes*, Instituto Superior Técnico, Lisboa, 1997.